

Studies of the Torsional Energy Required to Break Bean Pods under Drying Conditions

Toshio IWAO*. Hajime TANABE*

乾燥状態における豆の莢割れ捩れエネルギーに関する研究

岩尾俊男[※]・田辺一[※]

I. Introduction

The purpose of this study is to investigate the torsional energy required to break bean pods under various drying conditions, and to use the experimental results to elucidate the breaking situation after cutting in the field.

Generally, bean pods after cutting tend to break during drying in the field, resulting in field losses. Even a small impact produces breakage, and the broken pod twists.

Based on these facts, it is hypothesized that the case of breaking may be due to the torsional energy accumulated in the bean pods by drying in the field.

Therefore, this study is concerned with the relationship between moisture content and torsional energy of bean pods. In addition, it attempts to infer the relationship between breaking of bean pods and the relative humidity of air in the field.

However, field investigation will also be necessary because this study is vitally concerned with field conditions.

II. Experiment and Experimental Methods

1) Experimental Apparatus

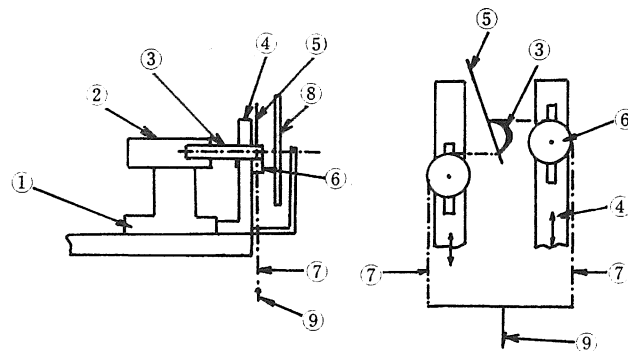

Fig. 1 Schematic torsional apparatus of a bean pod

- | | | |
|-----------------------------|--------------------------|-----------------------|
| ① Bench vise | ② Clamping part of a pod | ③ Test pod |
| ④ Holder of strings (steel) | ⑤ Needle | ⑥ Radial ball bearing |
| ⑦ String | ⑧ Goniometer | ⑨ Load |

* Laboratory of Agricultural Machinery.

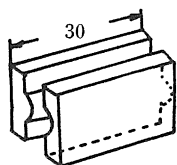

Fig. 2 Clamping part of a pod

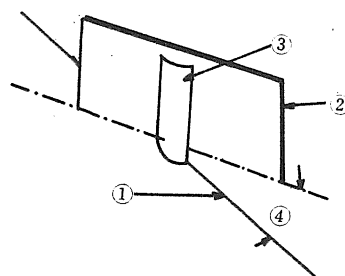

Fig. 3 Measurement of twisting angle of a test pod

- | | |
|-------------|------------------|
| ① Base line | ② Plate |
| ③ Test pod | ④ Twisting angle |

In Fig. 1, a schematic drawing of the torsional apparatus for bean pods is shown. This mechanism consists of a bench vise with rubber plates which had the shapes shown in Fig. 2 for the purpose of holding a test piece, goniometer and a loading apparatus to twist the bean pod.

To perform a test, one end of a bean pod was firmly grasped with the bench vise, and a needle with strings was fastened to the other end. Torsional load was applied to both strings over ball bearings. The loads used were 10, 30 and 50 g.

2) Material and Methods

Navy beans were used in this study. The bean pods were picked in the field. For the purpose of getting as nearly as possible the same length and shape, the bean pods used were selected by matching them to an archetype drawn on paper. The test pieces used were prepared by breaking the pod in half by hands. From the original end of each bean pod 15 mm of length were trimmed because of its unstable shape.

The total length of each test piece was 45 mm, and the length of the part clamped and the part to be twisted were 10 mm and 30 mm, respectively.

The twisting angles of test pieces 30 mm in length as a function of drying were determined by standing the piece on one end in line with a base line as shown in Fig. 3. A plate was then brought into contact in line with the upper end and the angle between plate and base line was measured.

Moisture absorption experiments were carried out in an Aminco-airounit under conditions of about 21°C and relative humidity ranging from 30 to 90%.

Two methods of moisture sorption were used. In one, the dried bean pods (about 7% moisture content) were successively brought to equilibrium at 30, 40, 50, 60, 70, 80, and 90% relative humidity.

In the other, the pods were first brought to equilibrium at 90% relative humidity followed by successive increments of desorption.

The moisture content of bean pods was calculated on a wet basis, after oven-drying for 48 hr. at 100°C. Pods and beans were dried separately.

A compression test and dropping test concerning the breaking energy of bean pods were briefly tried but the estimation of breaking energy was too difficult and the tests were not further pursued.

3) Shape of Experimental Material

In Fig. 4, the distribution of the straight, total length of 100 bean pods is shown. The moisture content of the pods was 9.2%, and the average length of bean pods was 77.8 mm.

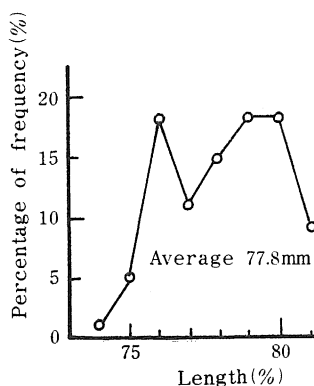

Fig. 4 Frequency distribution curve of total length of bean pods (based on 100 pods)

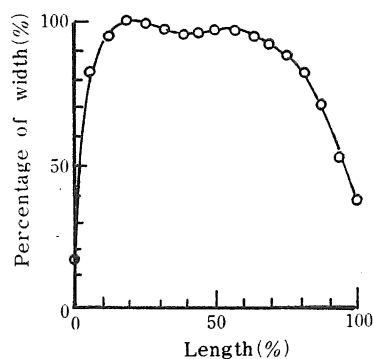

Fig. 5 Distribution of width of bean pods of 80mm in length (based on 10 pods)

Fig. 4 indicates that this experimental material was fairly uniform.

In Fig. 5, the average width at various distances from the end of bean pods 80 mm in length is shown, based on 10 pods. The average width was expressed as a percentage of the average maximum width of 100 pods.

The width of pods decreased rapidly at the ends. However, it was constant over about 60 % of the length with value larger than 90 %. This represented little change in width. Therefore results obtained with parts of relatively constant width should be fairly representative of the torsional character of bean pods.

In Fig. 6, the lengthwise distribution of circumferential length of pods is shown.

The circumferential length of pods was measured with calipers after cutting a string wound around a pod. The moisture content of pods was 9.2 %.

The results show that width and circumference are distributed very similarly. Hence, it was reasonable that both ends of the pods were cut off to make the test pieces.

In Fig. 7, the lengthwise distribution of the half circumferential length test specimens is shown, at a moisture content of 21 %.

The test pieces were pushed tightly onto paper, its outline marked with pencil, and then the half circumferential length was measured at intervals of 3 mm with calipers. In this case, it is clear that the half circumferential length of test specimens is gradually decreasing from one end to the other. Its total value decreased about 10 %.

Consequently, the half circumferential length of a pod can be represented by the average value at its ends. Therefore, for convenience, the latter was used for calculation.

III. Experimental Result

1) Relative Humidity and Moisture Content of Bean Pods

In Fig. 8, the relationship between relative humidity and moisture content of bean pods is shown, when the test material adsorbed moisture for 24 hours under the condition of 21°C in temperature and the range of 30 to 80 % relative humidity.

The moisture content of pods was about 10 % larger than that of beans.

Accordingly, it is reasonable that the moisture content of pods is used as a base of analysis, because the energy required to break pods only is of prime interest.

In Fig. 9, the relationships between relative humidity and moisture content of beans

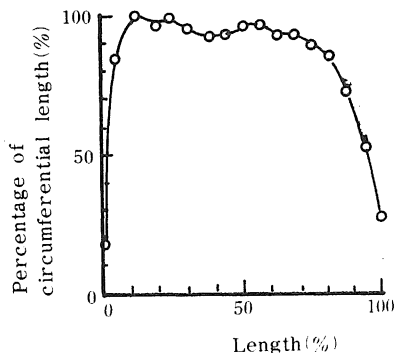

Fig. 6 Distribution of the circumferential length of bean pod (based on 10 pods)

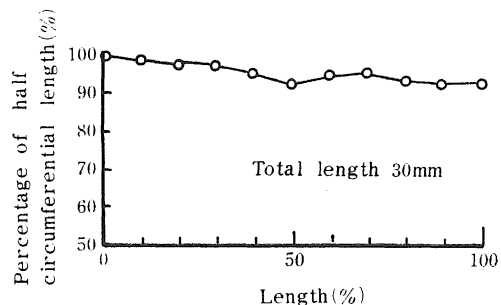

Fig. 7 Lengthwise distribution of the half circumferential length of test specimens (based on 10 pods)

and pods are shown, when the relative humidity conditions were decreased step by step every 24 hours after adsorption of moisture for 48 hours under the conditions of 21°C in temperature and 88% in relative humidity. The temperature was constant at 21°C.

In desorption, the moisture content of beans became higher than that of pods, the difference being less than about 5%. The moisture content of beans and pods decreased in proportion to the decrease in relative humidity.

Judging from these results, in torsional tests of a pods, the moisture content of the pod only must be used as the basis of comparison in examining the various factors included in this study.

In Fig. 10, the relationships between moisture content and desorption time are shown, when the bean pods were subject to desorption under the conditions of 20°C and 35% relative humidity after adsorption of moisture under conditions of 24°C and 88% relative humidity for 48 hours.

In this case, the pods reached near equilibrium in about six hours while the rate of desorption of the beans was much slower.

Accordingly, the condition of bean pods in the field after cutting might be inferred

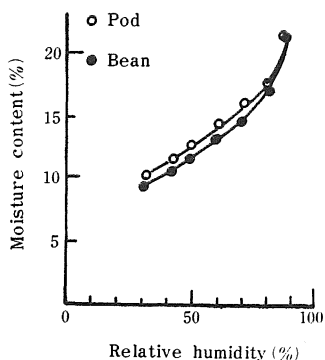

Fig. 8 Relationship between relative humidity and moisture content of pods (absorption of moisture 24 hours, temperature 21°C)

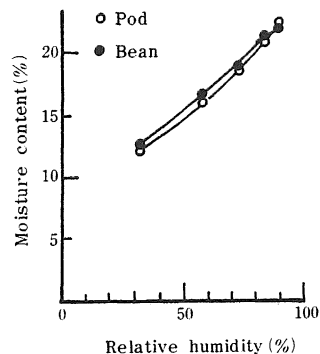

Fig. 9 Relationship between moisture content of bean or pod and relative humidity after absorption of moisture at 21°C and 88% R. H. for 48 hours

from above result. However, this represents results acquired under artificial drying conditions, which might differ from those in the field. The difference between moisture content of pods and beans after 24 hours at 20°C and 35% relative humidity was a small, and after 30 hours it was not evident.

2) Twisting angle and Moisture Content of Pods

In Fig. 11, the relationship between the twisting angle of test pieces 30 mm in length, and moisture content is shown. The twisting angles of pods decreased parabolical with increasing moisture content. Perhaps the twisting of pods might be due to differences in shrinkage during drying of pods.

To study this problem, it might be necessary to analyse the physical construction of pods.

3) Approximate Treatment of Pod cross-sectional shape ¹⁾

The torsion of pods was considered to resemble the torsion of a bar with narrow rectangular cross section. Thus, approximate solutions of the torsion of long narrow sections could be also used for calculating the torsional energy of pods.

Let the sides of the rectangular cross section be a and b, and the cross section be twisted by the torsional moment *T*. According to the theory of elasticity, in this case, the maximum torsional stress τ , the torsional angle per unit length θ , and the mean torsional energy per unit volume *U* are given as follows :

$$\tau = \frac{T}{k_1 ab^2} \dots\dots\dots (1)$$

$$\theta = \frac{T}{k_4 ab^3 G} = k_4 \frac{\tau}{bG} \dots\dots\dots (2)$$

$$U = \frac{k_1^2}{2k_4} \frac{\tau^2}{G} = k_6 \frac{\tau^2}{G} \dots\dots\dots (3)$$

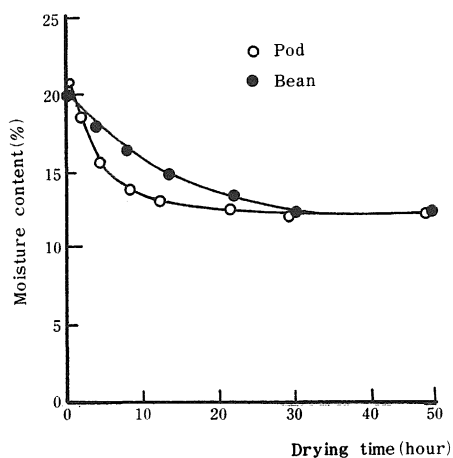

Fig. 10 Relationship between moisture content of bean pods and drying time under the condition of 20°C and 35% after absorption of moisture under the condition of 24°C and 87% R. H. for 48 hours

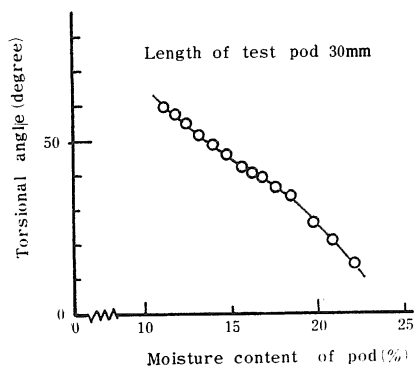

Fig. 11 Twisting angle and moisture content of test pods

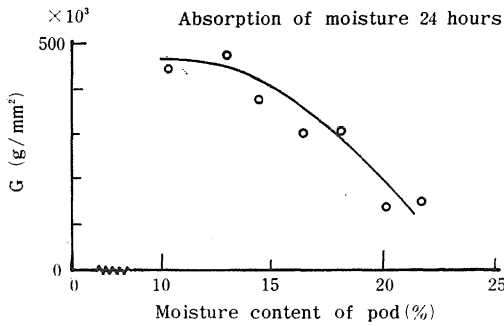

Fig. 12 Relationship between moisture content of pod and shear modulus G

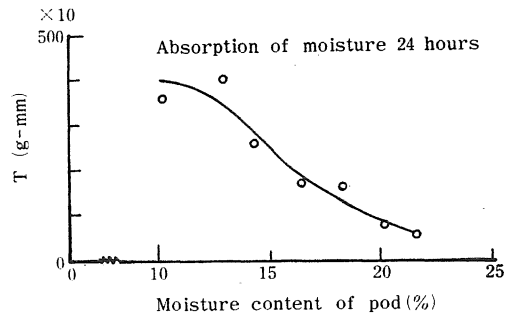

Fig. 13 Relationship between moisture content of pod and torsional moment T

In which, $k_5 = \frac{k_1}{k_4}$, and $k_6 = \frac{k_1^2}{2k_4}$.

The constants k_1 , k_4 , k_5 , and k_6 are given by nondimensional numbers as functions of $\lambda = a/b$, and the values of k_1 and k_4 are approximately given as follows :

$$k_1 = \frac{1}{3} \frac{\lambda}{\lambda + 0.6}, \text{ and } k_4 = \frac{1}{3} \left(1 - \frac{0.63}{\lambda} + \frac{0.052}{\lambda^4} \right) \dots\dots\dots (4)$$

If $\lambda > 4$,

$$k_1 = 0.289855, \text{ and } k_4 = 0.2809$$

Accordingly, it is apparent that k_1 and k_4 become nearly equal.

In the case of a pod, let the width and thickness be 10.7 and 0.216 mm respectively, and the values of k_1 and k_4 will be :

$$k_1 = \frac{1}{3} \frac{\lambda}{\lambda + 0.6} = 0.3294133$$

$$k_4 = \frac{1}{3} \left(1 - \frac{0.63}{\lambda} + \frac{0.052}{\lambda^4} \right) = 0.3291725$$

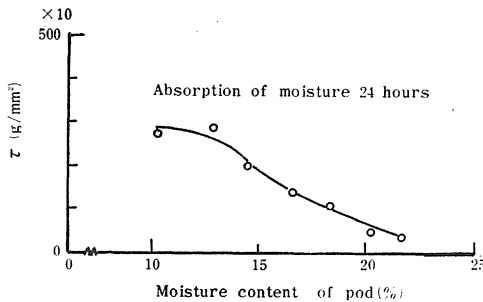

Fig. 14 Relationship between moisture content of pod and shearing stress

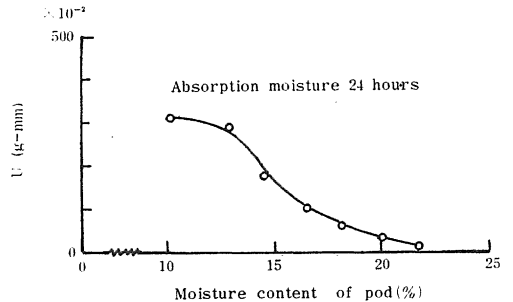

Fig. 15 Relationship between moisture content of pod and torsional energy U

therefore, $k_1 \cong k_4$.

4) Moisture Content of Pods and G , T , or U

In Fig. 12, the relationship between moisture content of pods and shear modulus G is shown under the condition of adsorption of moisture by pods every 24 hours.

Generally speaking, the values of G gradually increased with decreasing moisture content of pods. It was noticed especially that the values of G increased remarkably in the range of about 20 to 15 % moisture content. The values of G were in the range of about 150 to 400×10^3 g/mm².

In Fig. 13, the relationship between moisture content of pods and torsional moment, T , is shown under adsorption of moisture by pods in 24 hour steps.

The value of T was less than 100 g-mm at 20 % moisture content. The values of T were remarkably increased with decreasing moisture content of the pods. Other values of T were in the range of about 50 to 400 g-mm.

In Fig. 14, the relationship between moisture content of pods and unit shearing stress τ was shown under the condition of adsorption of moisture by pods in 24 hour steps. The shearing stress gradually increased with decreasing moisture content, and its values were in the range of about 30 to 300×10 g/mm².

In Fig. 15, the relationship between moisture content of pods and torsional energy U is shown under adsorption in 24 hour steps. It is clear that the torsional energy is remarkably increased with decreasing moisture content, and its value was in the range of about 10 to 300×10^{-2} g-mm.

In Fig. 16, the relationship between moisture content of pods and G , T , τ or U was shown under the condition of desorption, step by step, after initial adsorption for 48 hours.

The values of G , T , τ and U were remarkably increased with decreasing moisture content. This was the same tendency as under adsorption of moisture by pods in 24 hour steps.

It is apparent from the result that torsional energy increased with drying of pods and that this results in breakage.

Thus, it is reasonable that the moisture content of pods be the base for comparing various forces acting on the pods.

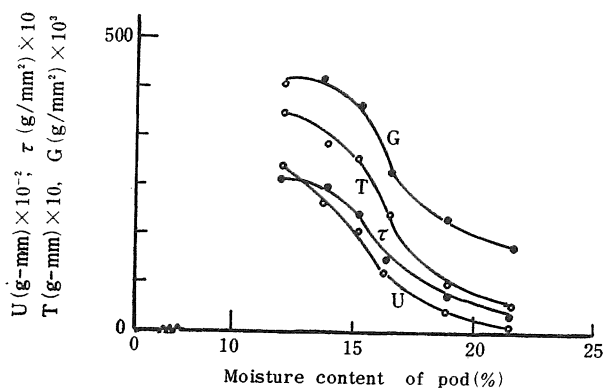

Fig. 16 Relationship between U , τ , T and G under the drying condition after absorption of moisture by pod for 48 hours in 22°C and 87%

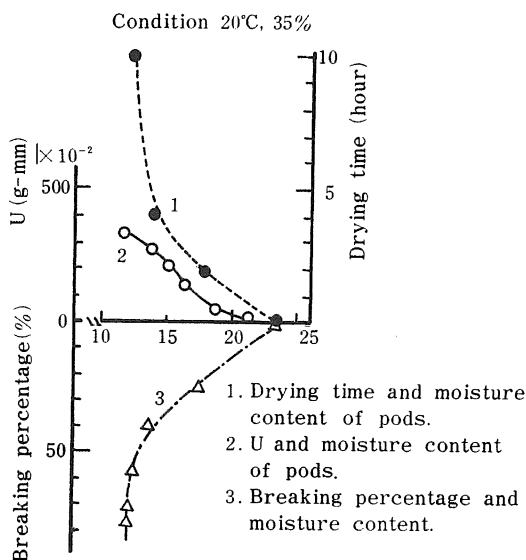

Fig. 17 Relationship between breaking percentages of damaged pods and the value of U in accordance with drying time under desorption after adsorption of moisture by pods for 48 hours in 20°C and 88%

5) Unit Torsional Energy U and Breaking percentage of damaged pods under drying conditions,

In Fig. 17, the relationship between breaking percentages of damaged pods and the values of U are shown under desorption at 20°C and 35% relative humidity after adsorption of moisture under the condition of 20°C in temperature and 88% in relative humidity for 48 hours.

The breaking percentages of pods were checked according to drying time. Thirty pods were used in every test, and the needless at the ends of the pods or 5 mm in length from the root of the needless were cut off to simulated bean pods damaged in the field.

From this result, it is apparent that the breaking percentage of bean pods may increase with drying time after cutting the beans in the field, and that the breaking is due to increasing values of U during drying.

This study took place under artificial drying conditions, so that this experimental result must be verified by a field test.

IV Summary

This study was concerned with the relationship between moisture content of pods and torsional energies required to break bean pods under artificial drying conditions. The torsional energy of bean pods was analysed by the method of the torsion of a bar with narrow rectangular section. Navy beans were used in this study.

The mean results were as follows :

1. The difference between the moisture content of beans and that of pods is due to the difference in the rate adsorption of moisture.
2. It is clear that the moisture content of the pod must be the basic factor to investigate.

3. As for the approximate treatment of the shape of pods, the torsion can be approximately considered as the torsion of a bar with narrow rectangular cross section.

4. The values of G , τ , T and U were in the range of about 150 to 500×10^3 g/mm², 30 to 300×10 g/mm², 50 to 400 g-mm and 10 to 350×10^{-2} g-mm, respectively. These values were remarkably increased with decreasing moisture content of pods.

5. It is apparent that the breaking percentage of bean pods is increased with drying time after cutting beans in the field.

6. This study took place under artificial drying condition, so that this experimental result must be verified by a field test.

Reference

- 1 Chi-Teh Wang : Applied Elasticity, Mcgraw-Hill, New York, 1953, p. 77-102

V 摘 要

この研究は、人工乾燥条件下での豆の莢の含水率と豆の莢割れ捩れエネルギーの関係を調べたものである。莢の捩れエネルギーは、薄肉矩形断面の棒の捩りと仮定して解析した値である。供試豆は Navy bean である。

主な結果は次の通りである：

1. 豆と莢の含水率の差は、水分の吸収量の差によるものである。
2. 豆と莢の含水率は、莢割れに関する研究の基準とすべきことが明らかになった。
3. 豆の莢の形状の近似的取り扱いとして、捩れは、近似的に薄肉矩形断面の棒の捩れとして考えることができる。
4. G , τ , T と U の値は、それぞれ約 $150 \sim 500 \times 10^3$ g/mm², $30 \sim 300 \times 10$ g/mm², $50 \sim 400$ g-mm と $10 \sim 350 \times 10^{-2}$ g-mm の範囲にあった。これらの値は、莢の含水率の減少により著しく増加した。
5. 豆の莢の莢割れ率は、圃場では豆を刈った後の乾燥時間の経過とともに増加することが明らかとなった。
6. この研究は人工乾燥条件下によるものであるので、これらの実験結果が圃場実験により確かめられることが望ましい。